

# FLIP CAP Protective Cap

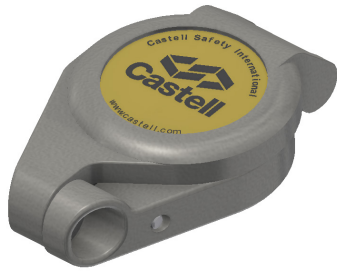

The Castell protective cap is used to help prevent dust ingress into the lock portion. The cap can easily be fitted to existing Castell locks. In addition, the cap can be also padlocked closed to prevent lock operation during maintenance.

## USAGE

The Castell FLIP-S is a stainless steel padlockable protective cap and is used to help prevent dust ingress into the lock.

1



2



3



## TECHNICAL DATA

<b>Temperature rating</b>	Minimum: -40°C [-40°F] ice free for Q & FS lock type
	Maximum: 107°C [224.6°F] for Q lock type/140°C [284°F] for FS lock type
<b>Weight</b>	0.1 kg
<b>Material</b>	Stainless steel

No hazardous substances were used in the manufacture of this product.

# FLIP CAP Protective Cap



## DRAWING

Dimensions: in mm

### FLIP-S (PADLOCKABLE)

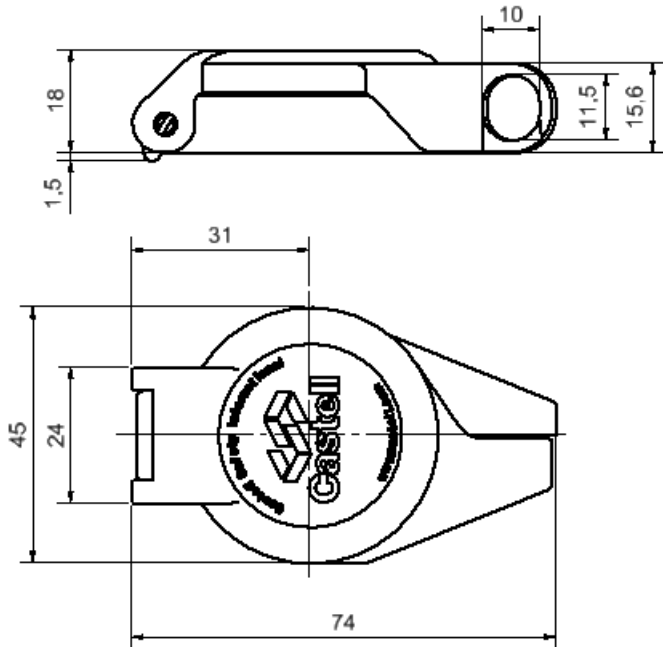

### FLIP-S NON PADLOCKABLE

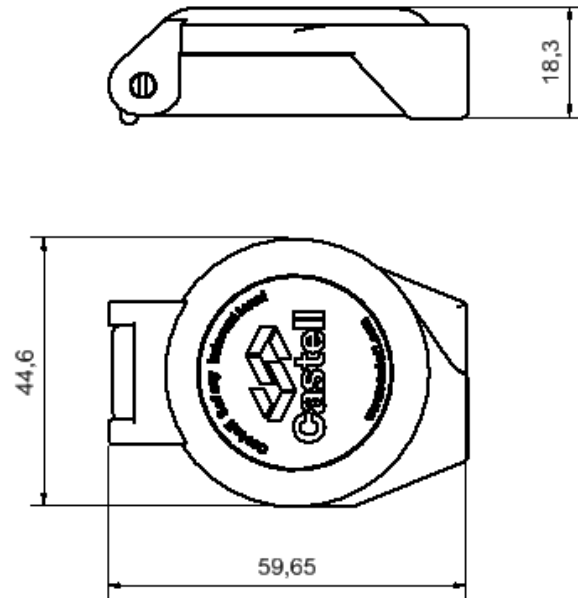

## ORDER INFORMATION

Part number **Component type** **1**  
 -



-



## CONTACT INFORMATION

#### Castell Safety

The Castell Building  
 217 Kingsbury Road  
 London, NW9 9PQ  
 UK

t: +44 (0)20 8200 1200  
 f: +44 (0)20 8205 0055  
 e: [sales@castell.com](mailto:sales@castell.com)

#### Castell Safety

Tower 185  
 60185 Frankfurt am Main  
 Germany

t: +49 (0)69 50 50 47 310  
 f: +49 (0)69 50 50 47 450  
 e: [vertrieb@castell.com](mailto:vertrieb@castell.com)

#### Kirk Key Interlock

9048 Meridian Circle NW  
 North Canton, OH 47720  
 USA

t: +1 800 438 2442  
 f: +1 330 497 4400  
 e: [sales@kirkkey.com](mailto:sales@kirkkey.com)

#### SPS China

2F, Building 63  
 No 421 Hongcao Road, Xuhui District  
 Shanghai PRC, 200233  
 China

t: +86 (0)21 6040 7398  
 f: +86 (0)21 5453 0630  
 e: [chinasales@castell.com](mailto:chinasales@castell.com)